

Concrete Tanks

Septic and Water Treatment Tanks

Turley's Precast Concrete Septic and Water Treatment Tanks are

Built to Last



- Certified to EN 12566-3
- Up to 99% BOD rating
- Easy Installation
- Superior to Plastic Tanks

Call us on: +44 (0)28 3026 6421 www.treatment-tanks.com

**Turley
Treatment
Tanks**

Turley's Precast Concrete Septic Tanks:

- **Are strong, durable and watertight**
- **Are easy to install – shallow dig design**
- **45 N concrete strength**
- **Utilise large volume capacities**



SPECIFICATIONS

The Turley Septic Tank

- Certified to EN12566-1
- 3400 Litre Capacity
- 45 Newton Concrete
- 4.7 Tonnes in Weight
- Up to 8 PE
- Length 3500mm
- Width 1300mm
- Height 1700mm (including lid and riser)
- Inlet 1310mm from bottom of tank (Invert level)

Turley's septic tanks are built to last. Unlike plastic and fibreglass alternatives, our precast concrete tanks are strong, durable and watertight. Furthermore, due to the nature of precast concrete, our tanks gradually strengthen over time.

Meeting all the definitions and mandatory standards of a septic tank in the European Union, our EN125661 certified Turley septic tank has a capacity of 3,400 litres. That's enough to solve the sewage disposal problem of an eight person home.

Concrete septic tanks are the ideal preferred storage vessel for on-site septic storage and treatment.

The Turley Septic Tank is made up of high strength 45 Newton concrete, and weighing in at 4.7 tonnes, is manufactured and

supplied from Turley's state of the art facility in Newry Co. Down. Whilst you can be reassured as to the robustness and effectiveness of our tanks, you don't need to worry about installation. Turley Bros will make the installation process easy and will install on site.

The high strength concrete tank design makes it free from seepage, leaking, and intrusion risks commonly

caused by roots from the vegetation in the vicinity and the acidity of the sewage. The Turley Septic Tank is designed with heavy duty HDPE risers and access covers, ventilation access, bitumen seal and pipe seal facilities at the inlet and outlet ends, is an ideal choice for not only new installations, but also is the tank of choice for replacement or upgrading of an existing tank.

Turley Bros are proud to announce that our Tank conforms to the current Standards of Environmental Practice as per the EPA Code of Practice and has achieved European EN 12566-1 certification.

Turley's Concrete Advanced Water Treatment Tanks:

- Are durable and affordable
- Utilise the latest water treatment equipment
- Have high effluent quality of 99% BOD
- Utilise natural bacteria
- We can offer advice on Consent to Discharge

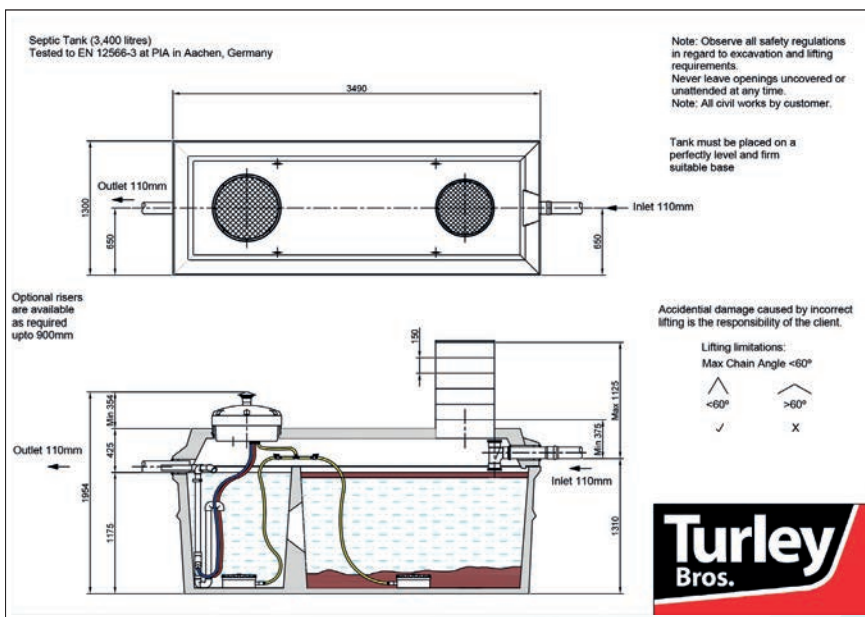

Turley's waste water treatment system tanks are durable and easy to install and can be utilised in those areas where the percolation area of the septic system does not meet the filtration requirements in terms of soil porosity.

The modern water treatment plant system fitted inside the concrete tank is protected by the robust concrete exterior.

PROCESS

Waste water enters through a calming inlet, minimizing disturbance. Inflowing wastewater is being intermittently aerated in both chambers.

This process reduces the overall sludge production. The total tank volume is being utilized as Reactor/ Sludge storage/ and buffer at different times within the 12 hour cycle.

This same 12 hr cycle enables the system to minimize the probability of hydraulic peaks occurring during sedimentation or clearwater discharge.

Turley Advanced Water Treatment System – EN 12566-3

Turley's Advanced Waste Water Treatment Systems combine the benefits and the durability from a concrete tank and the trusted performance of our SBR treatment kit.

Certified to be in compliance with the EN 12566-3 and the recent SR66 regulations.



SPECIFICATIONS

The Turley Advanced Water Treatment Tank

- Certified to EN12566-3
- 3400 Litre Capacity
- 45 Newton Concrete
- 4.7 Tonnes in Weight
- Up to 8 PE
- Length 3500mm
- Width 1300mm
- Height 1954mm (to top of control panel vent)
- Inlet 1310mm from bottom of tank (Invert level)

ConcreteTanks

Water Tank Accessories



WATER TANK ACCESSORIES

As well as supplying septic tanks, water treatment tanks and rainwater harvesting tanks, Turley Bros also supply a range of accessories including risers, lids and percolation boxes.

Please contact us with your requirements for new build, renovation or extension. We are more than happy to assist you with any technical queries and quote you for any of our products and services.

Tel: +44 (0)28 3026 6421
www.treatment-tanks.com

Why not come and visit our showroom and experience our products and finishes.



ACCESSORIES



LIDS

Plastic Risers:
150mm x 550 diameter
150mm x 650 diameter

ConcreteTanks

Septic and Water Treatment Tanks



/TurleyBros

Treatment Tanks is a trading name for Turley Bros' concrete septic and water tanks.
Tel: +44 (0)28 3026 6421 Fax: +44 (0)28 3025 0542 info@turleybros.com www.treatment-tanks.com
7 Corcreechy Road, Sheepbridge, Newry, Co Down BT34 1LP

**Turley
Treatment
Tanks**